

Wall Down Lite

Cat. No. DL

Cat. No. DL/LED

Cat. No. DL/R

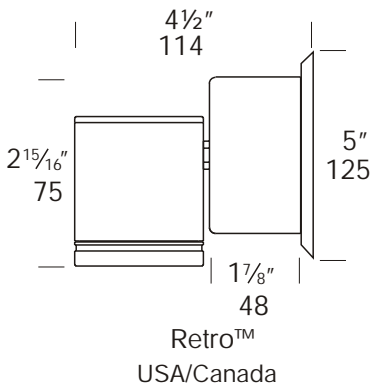
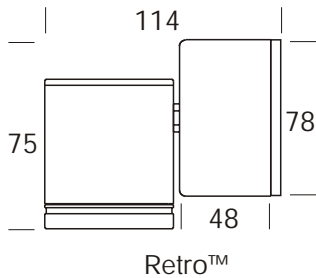
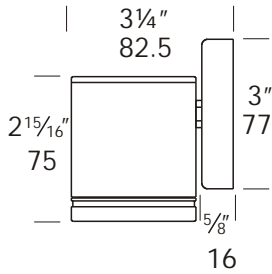

Suitable for mounting on timber, masonry, stone, etc. Non adjustable for one way wall washing, can be mounted with the lamp directed up or down. Water resistant with a 77mm diameter mounting base, complete with stainless steel screws.

The Retro™ is a 110/240 ac mains option suited to an installation where mounting a transformer is a problem, e.g. a brick wall where there is only the cable protruding out of the wall and it is not an option to recess the transformer or when replacing an existing light fitting. The base size increases in size to accommodate the encapsulated IP66 dimmable transformer.

Ordering Information

Luminaire Type

DL- Wall Down Lite

Material/Finish

BK - Black
 BZ - Bronze
 GN - Green
 MS - Metallic Silver
 WH - White

 COP - Copper
 SS - 316 Stainless Steel

Accessories

CJK150- Cable Joint Kit
 DFL- Frosted Lens
 GG- Glare Guard
 HCL- Hex Cell Louvre Adaptor
 LED- LED Array
 /TLED- Electronic LED Transformer
 (installed inside luminaire)
 /R- Retro™ Transformer 110/240 volt
 WBAP- Wall Box Adaptor Plate

Ordering Example

DL BK - Down Lite in Black
 DL/R SS - Down Lite Retro™ in 316 Stainless Steel

DFL - Frosted Lens

(Accessories ordered separately)



Patent Pending



FACTORY: Ph: 64-9-528 9471 Fax: 64-9-528 9361.
 USA: Ph. 310 560 7310 Fax. 1 877 692 4589.
 hunza@hunza.co.nz www.hunza.co.nz
 Specifications may change without notice.

130 Felton Matthew Ave, Glen Innes, Auckland, New Zealand.
 3237 Long Island St, W. Sacramento, California 95691, USA.
 Manufactured in New Zealand.

© 2003 Hunza Holdings Ltd

Luminaire Construction

CNC machined from the following metals:

Body: High corrosion resistant low copper 63.5mm (2½") x 10mm (25/64") aluminium. End cap - solid aluminium 63.5mm (2½") rod,.

Base & Mounting Plate (Retro™): Cast from virgin high corrosion resistant CC401 low copper aluminium alloy chromate substrate and high UV resistant polyester powder coat - Black, Bronze, Green, Metallic Silver, White.

Body: Copper 63.5mm (2½") x 10mm (25/64). End cap - solid copper 63.5mm (2½") rod.

Base: Copper Hand spun 2mm (5/64")

Mounting Plate: Forged brass (Retro™)

Body: Stainless steel 316 63.5mm (2½") x 10mm (25/64) rod. End cap - 316 stainless steel 63.5mm (2½") rod.

Base: Investment cast and CNC machined (Retro™).

Mounting Plate: Investment cast and CNC machined.

Mounting

12 volt: the luminaire is mounted to the wall using two 316 stainless screws through a shallow base 16mm (5/8") in depth. A Wall Box Adaptor Plate (Cat. WBAP) is available as an accessory to fit 3.0 and 4.0 junction boxes for USA /Canada.

Retro™ 110/240 volt: a mounting plate is fixed to the wall using two screws and the luminaire is fitted to the mounting plate.

Features

Lens:

3mm (1/8") thick clear tempered shatter resistant glass.

Life Time Warranty.

Gasket:

Silicone, iron impregnated 220°C (428°F).

Lamp Holder:

GU5.3 - 350°C (662°F) ceramic multi contact lamp holder with 250°C (480°F) teflon cables.

Accessories:

CJK150 Cable Joint Kit (Cat. CJK150)
Not approved for USA/Canada.

Frosted Lens (Cat. DFL).

Glare Guard (Cat. GG).

Hex Cell Louvre Adaptor (Cat. HCL)

CJK150 cable Joint Kit (Cat. CJK150)
Not approved for USA /Canada.

LED Array - Red, Blue, White, Yellow, Green (Cat. LED).

LED Transformer 100 - 240volt 6va. for inside the luminaire (Cat /TLED).

Retro™ transformer 110/240 volt (Cat. /R)

Wall Box Adaptor Plate (Cat. WBAP)
12 volt luminaire USA / Canada)

Standards

IP66  UL1838

Luminaire Weight

12 volt: Alum .460kg (1lb)
Cop 1.200kg (2lb 10oz)
SS 1.080kg (2lb 6oz)
Retro: Alum .780kg (1lb 11oz)
Cop 1.680kg (3lb 11oz)
SS 1.505kg (3lb 5oz)

Power Supply

HUNZA® Inground or Wall Mount
Transformer: not included.

HUNZA® H20/24LED: not included.

HUNZA® IG20/24LED: not included.

RETRO™

HUNZA® 110/240 volt ac silicone encapsulated electronic transformer built into the Retro™ base. Dimmable with a suitable leading edge dimmer.

Electronic transformer 100 - 240 volt 50/60Hz. 24 volt d.c. 6va: not included.

USA/ Canada

HUNZA® Wall Mount: not included
LED Electronic transformer 100 - 240 volt 50/60Hz. 24 volt d.c. 6va: not included.

Luminaire: supplied with

MR16 GU5.3 20, 35 or 50 watt lamp max.
LED Array 24 volt d.c. 1.2 watt.

USA and Canada

MR16 GU5.3 20 or 35 watt lamp.
LED Array 24 volt d.c. 1.2 watt.

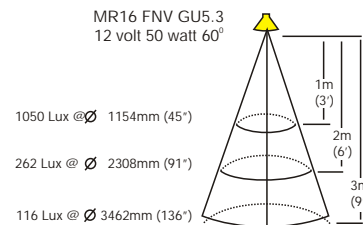
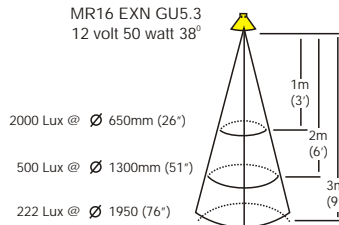
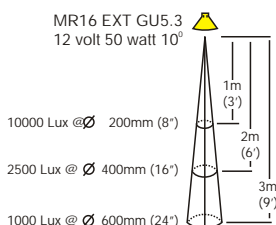
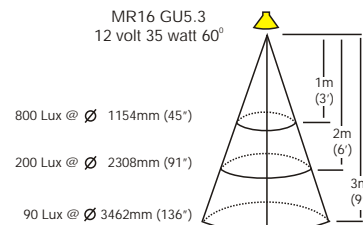
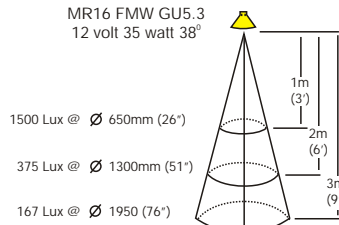
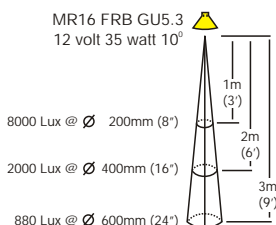
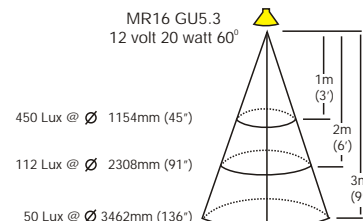
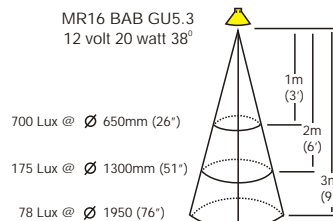
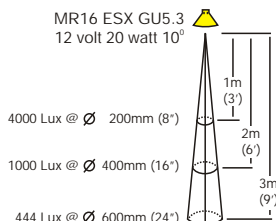

FACTORY: Ph: 64-9-528 9471 Fax: 64-9-528 9361.

USA: Ph. 310 560 7310 Fax. 1 877 692 4589.

hunza@hunza.co.nz www.hunza.co.nz

Specifications may change without notice.

130 Felton Matthew Ave, Glen Innes, Auckland, New Zealand.

3237 Long Island St, W. Sacramento, California 95691, USA.

Manufactured in New Zealand.

© 2003 Hunza Holdings Ltd