

Tree Mount

Cat. No. TMK



The Tree Mount Kit enables a HUNZA® NPS Spot to be mounted in a tree to create moon lighting effects. A cable connection can be made at the rear of the dome. The Kit consists of a mounting dome and tree 316 stainless steel bolts. The bolts initially fix the dome 40mm (1½") out from the tree's surface which allows the tree to grow without causing any harm.

Ordering Information

Luminaire Type

TMK - Tree Mount Kit

Material

Black Nylon 66

Accessories

CJK150 - Cable Joint Kit

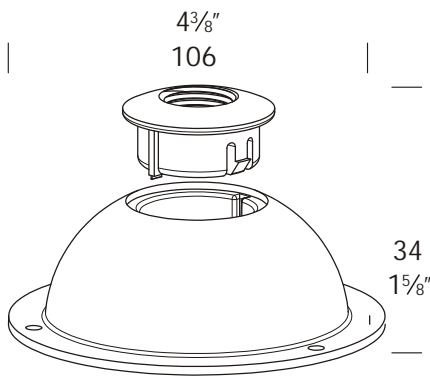

Ordering Example: TMK- Tree Mount Kit in Black

CJK150 - Cable Joint Kit

(Accessories ordered separately)



Patent Pending



FACTORY: Ph: 64-9-528 9471 Fax: 64-9-528 9361.
USA: Ph. 310 560 7310 Fax. 1 877 692 4589.
hunza@hunza.co.nz www.hunza.co.nz
Specifications may change without notice.

130 Felton Matthew Ave, Glen Innes, Auckland, New Zealand.
3237 Long Island St, W. Sacramento, California 95691, USA.
Manufactured in New Zealand.

© 2003 Hunza Holdings Ltd

Construction

Dome :

Molded from UV stable glass filled nylon 66 with snap in ½" NPS female adaptor.

Fixings supplied:

3 x 95mm (3¾") 316 stainless steel bolts.

3 x 3mm (1/8") 316 stainless steel screws.

Mounting

The Tree Mount dome is secured to the tree with 3 x 95mm (3¾") 316 stainless steel bolts. The HUNZA® NPS spot is screwed into the ½" nps adaptor.

Features

Dome:

The Dome is fixed 40mm (1½") out from the trees surface by three bolts allowing cabling to be run in behind the dome for connection to the luminaire.

Size:

½" NPS

Nylon 66:

UV stable glass filled, suitable for use with aluminium, copper and 316 stainless steel luminaires.

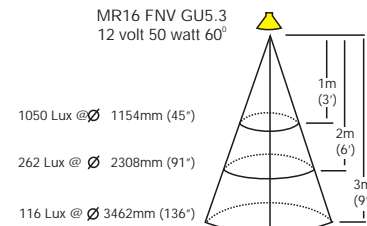
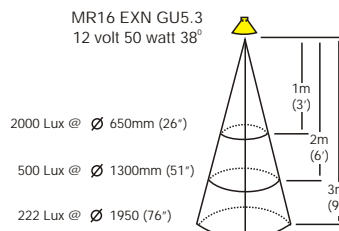
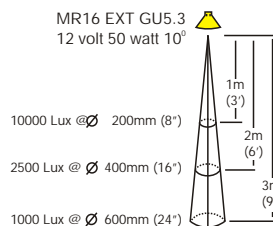
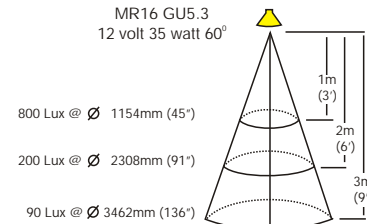
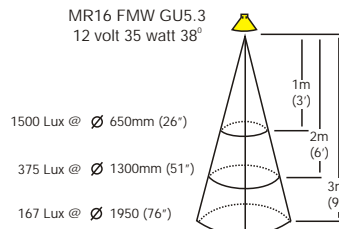
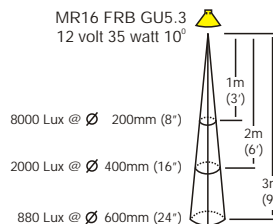
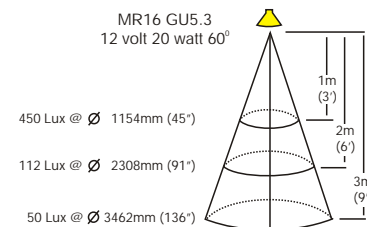
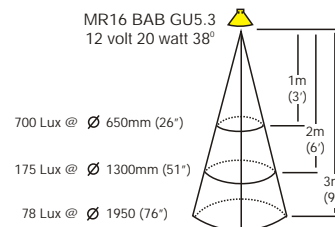
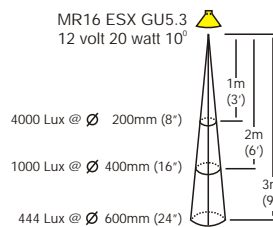

FACTORY: Ph: 64-9-528 9471 Fax: 64-9-528 9361.
USA: Ph. 310 560 7310 Fax. 1 877 692 4589.
hunza@hunza.co.nz www.hunza.co.nz
Specifications may change without notice.

130 Felton Matthew Ave, Glen Innes, Auckland, New Zealand.
3237 Long Island St, W. Sacramento, California 95691, USA.
Manufactured in New Zealand.

© 2003 Hunza Holdings Ltd