

Step Lite Solid Eyelid

Cat. No. SLs
Cat. No. SLsfl



The Solid Eyelid Step Lite has a smooth machined finish without mounting holes to disrupt the elegant line of the fitting and is designed to fit into a mounting canister. The eyelid masks two thirds of the lamp which eliminates all upward light.

A 240 volt fluorescent option is available which offers excellent light output, low energy usage and very low heat generation this changes the luminaire to an IP66 rating.

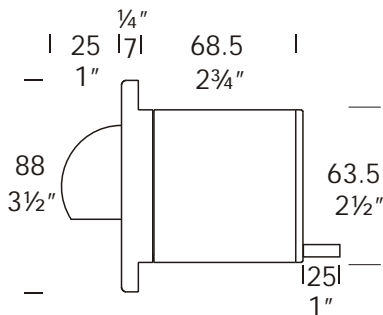

Ordering Information

Luminaire Type

SLs - Step Lite
Solid Eyelid

Material/Finish

BK - Black
BZ - Bronze
GN - Green
MS - Metallic Silver
WT - White

COP - Copper
SS - 316 Stainless Steel

Accessories

CJK150 - Cable Joint Kit
FL - Fluorescent Option
HCL - Hex Cell Louvre Adaptor
Slican - Step Lite Canister
Canss - Stainless Canister
Flucan - Fluorescent Canister PVC

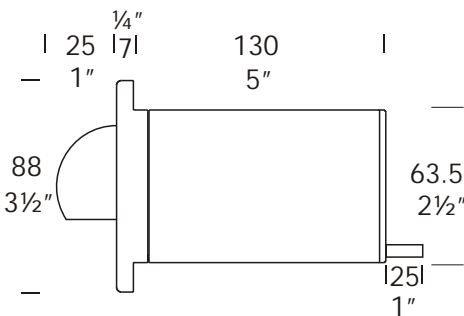

Fluorescent Option



Ordering Example

SLs SS - Step Lite in 316 Stainless Steel
SLsfl COP - Step Lite in Copper with
Fluorescent option

HCL COP - Hex Cell Louvre in Copper

(Accessories ordered separately)

Patent Pending



FACTORY: Ph: 64-9-528 9471 Fax: 64-9-528 9361.
USA: Ph. 310 560 7310 Fax. 1 877 692 4589.
hunza@hunza.co.nz www.hunza.co.nz
Specifications may change without notice.

130 Felton Matthew Ave, Glen Innes, Auckland, New Zealand.
3237 Long Island St, W. Sacramento, California 95691, USA.
Manufactured in New Zealand.

© 2003 Hunza Holdings Ltd

Luminaire Construction

CNC machined from one of the following metals:

High corrosion resistant 63.5mm (2½") x 10mm (25/64") aluminium.
End cap - solid aluminium 63.5mm (2½") rod, flange 90mm (3½") solid aluminium rod with chromate substrate and high UV resistant polyester powder coat -

Colours Black, Bronze, Green, Metallic Silver, White.

Copper: 63.5mm (2½") x 10mm (13/32"). End cap - solid copper 63.5mm (2½") rod.
Flange 90mm (3½") solid copper rod.

316 Stainless steel: 9mm (11/32"). End cap - solid 316 stainless steel 63.5mm (2½") rod.
Flange 90mm (3½") solid 316 stainless steel rod.

Mounting

Designed to fit through a 66mm (2 5/8") hole and be fixed into position by two screws in the flange or a Step Lite canister (see accessories) can be used which maintains the aesthetic look of the flange by eliminating the two screw holes in the flange.

Features

Lens:
3mm (1/8") thick clear tempered shatter resistant glass.

Life Time Warranty.

Gaskets:
Silicone, iron impregnated 220°C (428°F).

Lamp Holders:
GU 5.3 - 350°C (662°F) ceramic multi contact lamp holder with 250°C (480°F) teflon cables.

Fluorescent
E27 PET 210° (410°F) base mount.

Accessories:

Cable Joint Kit (Cat. CJK 50)
Not approved for USA /Canada.

Fluorescent Canister , PVC (Cat. Flucan).

Fluorescent Option 5 watt 240 volt (Cat. FL) IP66.

Frosted Lens (Cat. DFL).

Hex Cell Louvre Adaptor (Cat. HCL).

Step Canister (Cat. Slcan).

316 Stainless Canister for use in lime stone etc. (Cat. Canss).

Standards

IP66 / IP68



UL1838

Luminaire Weight

12 volt
Alum .485kg (1lb 1oz)
Cop 1.385kg (3lb)
SS 1.130kg (2lb 7oz)

Fluorescent IP66
Alum .800kg (1lb 12oz)
Cop 2.320kg (5lb 1oz)
SS 1.765kg (3lb 14oz)

Power Supply

HUNZA® Inground or Wall Mount
Transformer: not included.

USA and Canada:

HUNZA® Wall Mount Transformer:
not included.

Luminaire: supplied with

Halogen
MR16 GU5.3 20 watt lamp max.

Fluorescent
E27 - 240 volt 5 watt self ballasted
lamp.

USA and Canada:
MR16 GU5.3 20 watt lamp max.

Step Lite Eyelid Square 20 watt - Lens height 400mm (15¾")

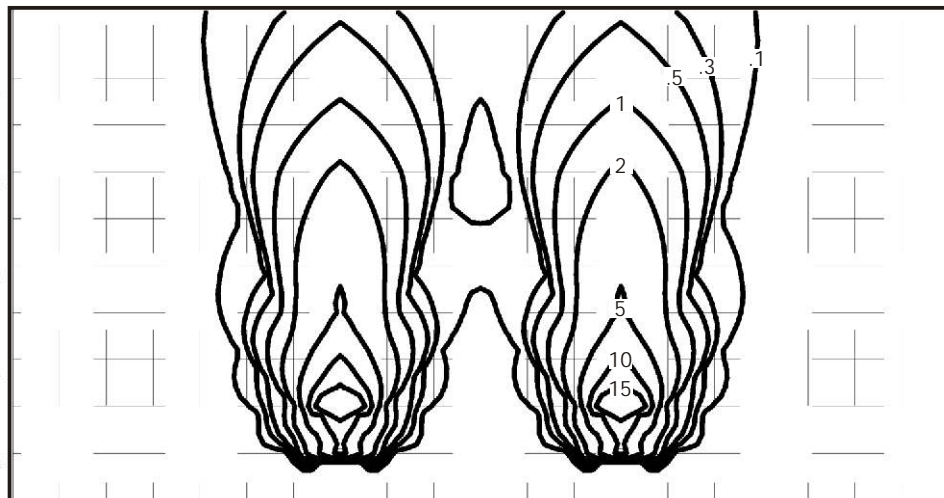
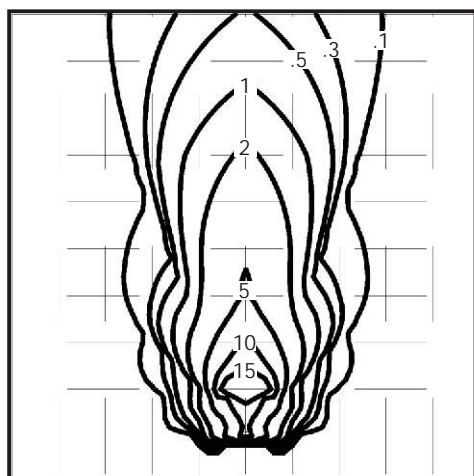

Isolux Lumens Plot - Footcandles = Isolux figures divided by 10.76



FACTORY: Ph: 64-9-528 9471 Fax: 64-9-528 9361.
USA: Ph. 310 560 7310 Fax. 1 877 692 4589.
hunza@hunza.co.nz www.hunza.co.nz
Specifications may change without notice.

130 Felton Matthew Ave, Glen Innes, Auckland, New Zealand.
3237 Long Island St, W. Sacramento, California 95691, USA.
Manufactured in New Zealand.

© 2003 Hunza Holdings Ltd