

Inground 1-11

Cat. No. IG1-11



The Inground 1-11 is suitable for use with 50, 75 and 100 watt lamps which have a range of beam angles from 8 to 45 degrees and is complete with its own 120 or 240 volt ac integral power supply and thermal over load and is dimmable. The AR1-11 lamp has very low glare output due to the dome covering the halogen capsule. The luminaire can be driven over 10km max (6 mph) maximum vehicle weight 1500 kg (3000lbs) or walked upon without damaging it and it has a 'Flush Fit' lens which stops water pooling and depositing dirt on the lens.

The Inground 1-11 is supplied with a mounting canister. The lamp can be directed (up to 20 degrees) without the need to remove the fitting from the canister due to the vandal-resistant four allen head screw fixing system which attaches the flange to the body of the luminaire.

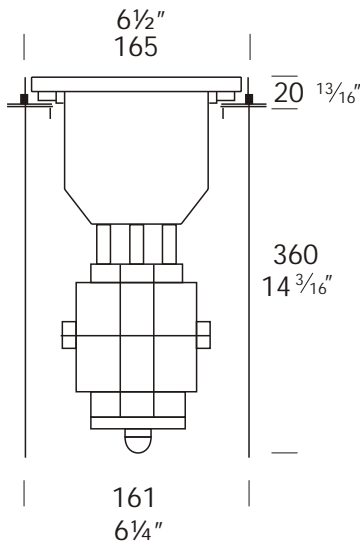

Ordering Information

Luminaire Type

IG1-11 - Inground 1-11

Flange Option

BZ - Bronze
SS - 316 Stainless Steel

Body

Black only

Accessories

IGFL - Frosted Lens



Ordering Example: IG1-11 BZ - Inground 1-11 with Bronze Flange

IGFL - Frosted Lens

(Accessories ordered separately)



FACTORY: Ph: 64-9-528 9471 Fax: 64-9-528 9361.
USA: Ph. 310 560 7310 Fax. 1 877 692 4589.
hunza@hunza.co.nz www.hunza.co.nz
Specifications may change without notice.

130 Felton Matthew Ave, Glen Innes, Auckland, New Zealand.
3237 Long Island St, W. Sacramento, California 95691, USA.
Manufactured in New Zealand.

© 2003 Hunza Holdings Ltd

Luminaire Construction

Body

Cast from virgin high corrosion resistant CC401 low copper aluminium alloy, with chromate substrate and high UV resistant black polyester powder coat.

Flanges

The flange is attached to the body by four 316 stainless steel allen head anti vandal screws and is available in either -

Solid bronze -170mm (6 1/2") bar.

Solid 316 Stainless Steel 170mm (6 1/2") bar rod.

Mounting

The Inground 1-11 supplied with a mounting canister for casting in concrete. The fitting can be driven over or walked upon without damaging it. Maximum drive over speed 10 km/h (6 mph) and maximum vehicle weight 1500 kg (3300lbs).

Features

Lens:

12mm (1/2") thick 'Flush Fit' clear tempered shatter resistant glass.

Life Time Warranty

Gasket:

Silicone, iron impregnated 220°C (428°F).

Lamp Holder:

GU53: Lamp cradle can be rotated 360° and angled up to 20°.

Accessories:

Frosted Lens (Cat. IGFL).

Standards

IP66



UL1598

Power Supply

HUNZA® built in transformer.
Input: voltage 240 volt ac 50Hz.

USA and Canada

Input voltage: 120 volt ac 60 Hz.

Luminaire: supplied with

GU53 - 50, 75 or 100 watt lamp max.

Beam Angles

8°, 24° and 45°

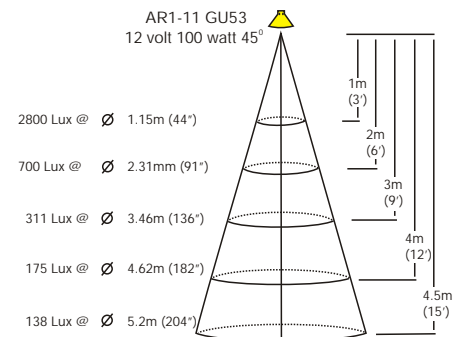
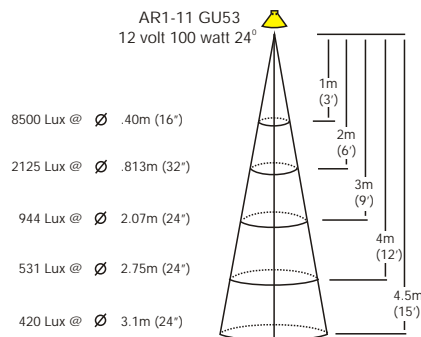
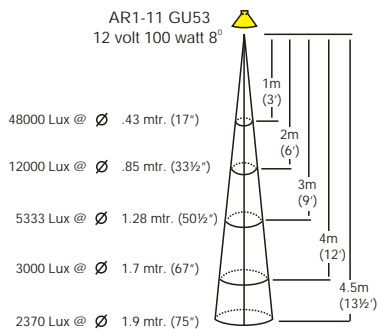

FACTORY: Ph: 64-9-528 9471 Fax: 64-9-528 9361.
USA: Ph. 310 560 7310 Fax. 1 877 692 4589.
hunza@hunza.co.nz www.hunza.co.nz
Specifications may change without notice.

130 Felton Matthew Ave, Glen Innes, Auckland, New Zealand.
3237 Long Island St, W. Sacramento, California 95691, USA.
Manufactured in New Zealand.

© 2003 Hunza Holdings Ltd