

# Euro Spot

Cat. No. ES

Cat. No. ESS



The Euro Spot is for situations where the luminaire needs to be concealed, the smaller sized MR11 lamp is utilised to achieve. It has a built in glare guard.

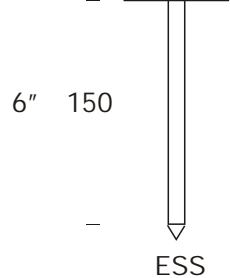
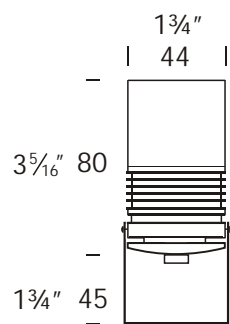
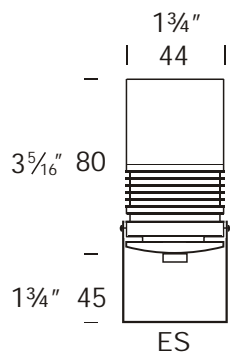

## Ordering Information

### Luminaire Type

ES - Euro Spot

### Material

COP - Copper  
SS - 316 Stainless Steel

### Accessories

CJK150 - Cable Joint Kit  
EFL - Frosted Lens  
S - 150mm (6") Spike

Ordering Example

ES COP - Euro Spot in Copper

ESS SS - Euro Spot in 316 Stainless

Steel 150mm (6") Spike

*(Accessories ordered separately)*



FACTORY: Ph: 64-9-528 9471 Fax: 64-9-528 9361.  
USA: Ph. 310 560 7310 Fax. 1 877 692 4589.  
hunza@hunza.co.nz www.hunza.co.nz  
Specifications may change without notice.

130 Felton Matthew Ave, Glen Innes, Auckland, New Zealand.  
3237 Long Island St, W. Sacramento, California 95691, USA.  
Manufactured in New Zealand.

© 2003 Hunza Holdings Ltd

## Luminaire Construction

CNC machined from one of the following metals:

Body:

Copper 45.4mm (13/4") rod.

"U" Bracket:

12 x 3mm (1/2" x 1/8") copper.

Spike:

11mm x 150mm (3/8" x 6") copper.

Body:

Stainless steel 316 45.4mm (13/4") rod.

"U" Bracket:

12 x 3mm (1/2" x 1/8") Stainless steel 316.

Spike:

11mm x 150mm (3/8" x 6") Stainless steel 316.

## Mounting

ES:

Via a "U" bracket that is screwed to the mounting surface.

ESS:

Ground spike 150mm (6") or 300mm (12") mounted directly into the ground.

## Features

**Lens:**

3mm (1/8") clear tempered shatter resistant glass.

Life Time Warranty.

**Gaskets:**

Silicone, iron impregnated 220°C (428°F).

**Lamp Holder:**

GU4 - 350°C (662°F) ceramic multi contact lamp holder with 250°C (480°F) teflon cables.

**Cable:**

1.3mm (16AWG) x 3 metres (9') submersible cable, longer cables available on request.

**Accessories:**

Cable Joint Kit (Cat. CJK150)

Frosted Lens (Cat. EFL).

Ground Spike 150mm (6") (Cat. S).

## Standards

**IP66**

**USA and Canada:**

Not Approved

**Luminaire Weight**  
(including cable)

ES

Cop .860Kg (1lb 14oz)

SS .815Kg (1lb 12oz)

ESS

Cop .970Kg (2lb 2oz)

SS .930Kg (2lbs)

**Power Supply**

HUNZA® Inground or Wall Mount  
Transformer: not included.

**Lamp Type**

MR11 GU4 - 20 watt lamp max.

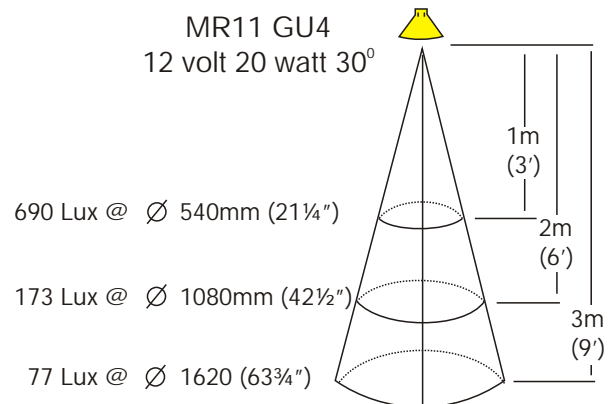
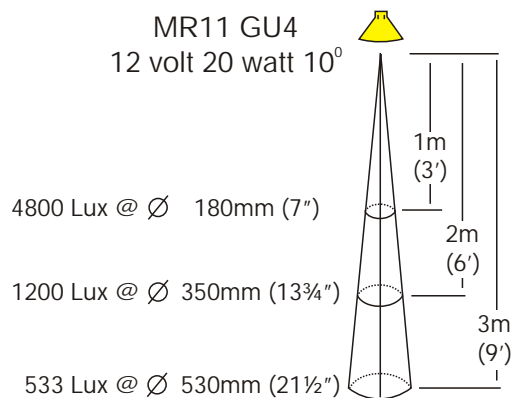

FACTORY: Ph: 64-9-528 9471 Fax: 64-9-528 9361.

USA: Ph. 310 560 7310 Fax. 1 877 692 4589.

hunza@hunza.co.nz www.hunza.co.nz

Specifications may change without notice.

130 Felton Matthew Ave, Glen Innes, Auckland, New Zealand.

3237 Long Island St, W. Sacramento, California 95691, USA.

Manufactured in New Zealand.

© 2003 Hunza Holdings Ltd